

Space-saving Signal Conditioners M3-UNIT Series

UNIVERSAL TRANSMITTER
(field- and PC-configurable)

MODEL **M3LU**

MODEL & SUFFIX CODE SELECTION

M3LU-□/□□

MODEL _____

INPUT SELECTION

◆DC Current & Voltage

Current: Usable range 0 – 20mA; min. span 1mA

Millivolt: Usable range ±1V; min. span 4mV

Voltage: Usable range ±10V; min. span 1V

◆Thermocouples

(PR), K, E, J, T, B, R, S, C (WRe 5-26),
N, U, L, P (Platinel II)

◆RTD

Pt 100, Pt 200, Pt 300, Pt 400, Pt 500, Pt 1000,
Ni 100, Ni 120, Ni 508.4, Ni-Fe 604,
Cu 10 @25°C, Pt 50Ω, JPt 100

◆Potentiometers

Total resistance 80Ω – 4000Ω

◆Resistance

Total resistance 10Ω – 4000Ω

OUTPUT SELECTION

◆DC Current: Usable range 0 – 20mA; min. span 1mA

◆DC Voltage

Narrow Spans: Usable range ±2.5V; min. span 250mV

Wide Spans: Usable range ±10V; min. span 1V

POWER INPUT _____

M2 : 100 – 240V AC

R4 : 10 – 32V DC

CONFIGURATION OPTIONS _____

A : PC and field configurable

B : Field configurable

OPTIONS _____

/UL : UL approval

(selectable only with DC power input code R4)

ORDERING INFORMATION

Special code number. Orders will be shipped at default factory settings (4 – 20mA input/4 – 20mA output).

Ordering example:

- Code number (e.g. M3LU-R4/A)

RELATED PRODUCTS

- PC configurator software (model: M3CON)
Downloadable at M-System's web site:
<http://www.m-system.co.jp>
- PC configurator cable (model: MCN-CON)

GENERAL SPECIFICATIONS

Connection: Removable terminal block

Housing material: Flame-resistant resin (grey)

Isolation: Input to output to power

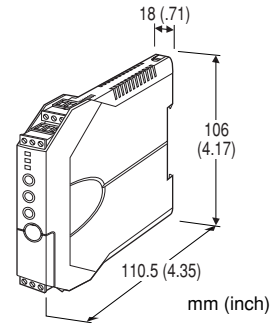

Functions & Features

- Universal input: mV, V, mA, T/C, RTD, resistance and potentiometer
- Easy 'One-Step Cal' calibration using the front three control buttons without needing a PC; PC software is also usable.
- Both input and output type and range are configurable
- UL approval

Typical Applications

- Signal conversion between control room and field instrumentation with isolation
- Ideal for use as a fast solution, multifunctional spare part

Overrange output: Approx. -15 – +115%

(Negative current output is not available even within this range.)

Fine zero and span adjustments: ±15% via the front control buttons

Burnout (T/C & RTD): Upscale, downscale or no burn-out selectable; Also detects wire breakdown and overrange input exceeding the electrical design limit for DC input.

Cold Junction Compensation (T/C): CJC sensor (included) to be attached to the input terminals

Configuration

'One-Step Cal' calibration: With I/O type and the full-scale range configured via the internal DIP switches, precise 0% and 100% ranges are calibrated via the front control buttons with a help of LED.

PC configurator (model: M3CON): Via Windows PC connected to the front jack.

Programmable features include:

- I/O type and range
- Zero and span adjustments
- Burnout

Status indicator LED: Tri-color (green/amber/red) LED; Flashing patterns indicate operation status of the transmitter.

INPUT

Input type and range are configurable. See Table 11 for the available input type, the minimum span, the maximum range, the conformance range and the input conversion accuracy.

■ **DC CURRENT:** 50Ω resistor incorporated (0.5W)

■ **DC mV & VOLTAGE**

Input resistance: 1MΩ minimum

■ **THERMOCOUPLE**

Input resistance: 1MΩ minimum

Burnout sensing: 130nA ±10%

■ **RTD** (2-wire, 3-wire or 4-wire)

Excitation: 0.2mA ±10%

Allowable leadwire resistance: 20Ω per wire

■ **POTENTIOMETER**

Excitation: 0.2mA ±10%

Allowable leadwire resistance: 20Ω per wire

■ **RESISTANCE** (2-wire, 3-wire or 4-wire)

Excitation: 0.2mA ±10%

Allowable leadwire resistance: 20Ω per wire

OUTPUT■ **DC CURRENT**

Maximum range: 0 – 20mA DC

Minimum span: 1mA

Conformance range: 0 – 24mA DC

Offset: Lower range can be any specific value within the input range provided that the minimum span is maintained.

Load resistance: Output drive 15V maximum at 22mA

(Range) 0 – 20mA : 750Ω maximum

■ **DC VOLTAGE**

Narrow Spans (mV)

Maximum range: -2.5 – +2.5V DC

Minimum span: 250mV

Conformance range: -3 – +3V DC

Wide Spans (V)

Maximum range: -10 – +10V DC

Minimum span: 1V

Conformance range: -11.5 – +11.5V DC

Offset: Lower range can be any specific value within the input range provided that the minimum span is maintained.

Load resistance: Output drive 10mA maximum; 5mA for negative output

(Range) 0 – 10V : 1k (Ω minimum)

-10 – 0V : 2k

0 – 2.5V : 250

-2.5 – 0V : 500

INSTALLATION**Power input**

AC: Operational voltage range 85 – 264V AC; 47 – 66 Hz; approx. 4VA at 100V
approx. 5VA at 200V
approx. 6VA at 264V

DC: Operational voltage range 9 – 36V DC; approx. 2W; ripple 10% p-p max.

Operating temperature: -25 to +65°C (-13 to +149°F)
Max. 55°C (131°F) for UL approval

Operating humidity: 0 to 95% RH (non-condensing)

Mounting: DIN rail

Dimensions: W18×H106×D110.5 mm
(0.71"×4.17"×4.35")

See General Spec. Sheet Figure A-1.

Weight: 100 g (0.22 lbs)

Terminal assignment: See General Spec. Sheet Figure B-2.

PERFORMANCE

Accuracy: See Table 11.

Cold junction compensation error:

±0.5°C maximum at 10 – 40°C

±1.0°C maximum at 0 – 50°C

±0.9°F maximum at 50 – 104°F

±1.8°F maximum at 32 – 122°F

Temp. coefficient: ±0.015%/°C (±0.008%/°F)*

at -5 to +55°C [23 to 131°F] of max. range

Response time: ≤0.2 sec. (0 – 90%, DC input)**

Burnout response: ≤10 sec.

Line voltage effect: ±0.1% over voltage range

Insulation resistance: ≥100MΩ with 500V DC

Dielectric strength

AC powered: 2000V AC @1 minute

(input to output to power to ground)

DC powered: 1500V AC @1 minute

(input to output or power to ground)

500V @1 minute (output to power)

*±0.03%/°C (±0.016%/°F) for the following conditions: DC/TC input spans ≤10mV; RTD/POT, resistance spans ≤80Ω; in an ambient exceeding 55°C (131°F) or below -5°C (23°F).

**With the Option A, the Sync Filter set to the fastest frequency on the PC Configurator Software. Default is set to have 0.5 sec. response.

STANDARDS & APPROVALS

CE conformity: EMC Directive (89/336/EEC)

EMI EN61000-6-4

EMS EN61000-6-2

Low Voltage Directive (73/23/EEC)

EN61010-1

Installation category II

Pollution degree 2

Max. operating voltage 300V

Input or output to power – Reinforced insulation

Input to output – Basic insulation

Approval: UL/C-UL general safety requirements

(UL 61010-1, CAN/CSA-C22.2 No.1010-1)

SCHEMATIC CIRCUITRY & CONNECTION DIAGRAM

DC POWERED TYPE

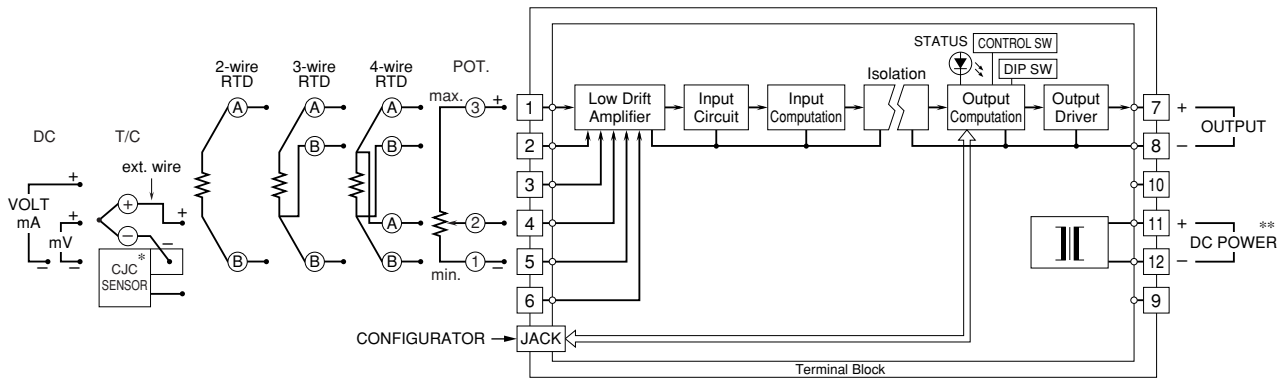

AC POWERED TYPE

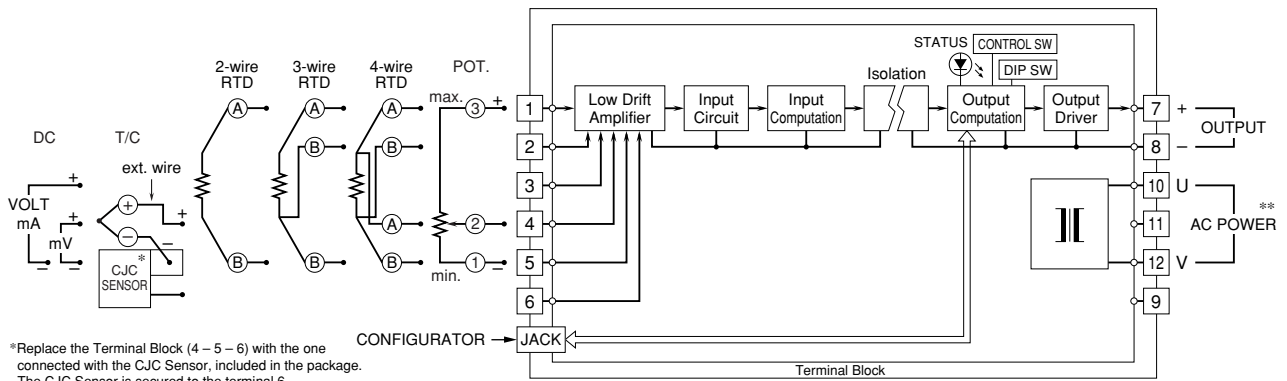

*Replace the Terminal Block (4 – 5 – 6) with the one connected with the CJC Sensor, included in the package. The CJC Sensor is secured to the terminal 6. Loosen only the terminal 4 – 5 and connect the T/C extension wires.

**Be aware that the AC power and DC power connect to different terminals.

EXTERNAL DIMENSIONS & TERMINAL ASSIGNMENTS mm (inch)

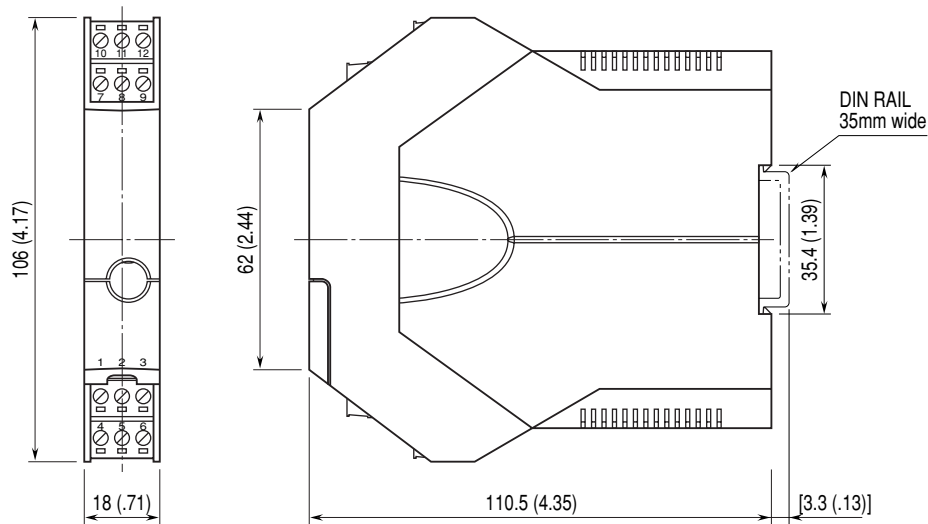

•When mounting, no extra space is needed between units.

ONE-STEP-CAL CALIBRATION

CONFIGURATION MODES & DIP SW

When you program the transmitter module, two configuration modes are available: Field Configuration using DIP SW / control buttons, and PC Software. (Option B type is for the field configuration only.)

The internal DIP switches are used to configure input and output type. Once the module is configured, precise ranges are set up with the front control buttons using a simulator connected to the input terminals and a multimeter connected to the output terminals as a reference.

INPUT & OUTPUT RANGING

For example, suppose that the DIP switches are configured for the J type thermocouple (-210 – +1200°C full-range). Turn the power supply to the transmitter on and press MODE button to enter to the Input Calibration Mode. Apply the desired minimum (e.g. 0°C) and maximum (e.g. 400°C) input levels and push the DOWN (zero) and UP (span) respectively to set the input range to 0 – 400°C.

Then the output range can be calibrated in a similar manner after moving to the Output Calibration Mode by pressing MODE button again. Increase or decrease the simulated input until the output meter shows the desired levels and push the DOWN (zero) and UP (span) respectively for the minimum (e.g. 4mA) and maximum (e.g. 20mA) levels.

The front LEDs' colors and flashing patterns help you to easily identify the transmitter's status and confirm the setup actions in each step of Calibration Modes. See detailed explanation in "Calibration Flow Chart."

The calibrated input and output ranges are stored in the internal memory. The module reads the DIP-switch-calibrated configuration only once after the power supply is turned on. Set the switches with the power supply removed.

FINE ZERO & SPAN ADJUSTMENTS

After the transmitter is installed and operational, fine zero and span tuning can be also performed using the front control buttons. Both zero and span are adjustable within ±15%.

PC SOFTWARE CONFIGURATION

When you need to apply the same setting to multiple transmitters, downloading one setting from the PC is convenient. The PC Configurator Software (model: M3CON) is available separately.

Turn the transmitter to PC Configuration Mode (See Table 1 below) and all programmable features can be set up on a PC regardless of other DIP SW setting except for: (1) JP2 to be switched from 1 – 2 to 2 – 3 for DC voltage input (See Notes under Table 2), and (2) the output type must be selected with the DIP SW1-1 through SW1-4 (See Table 10).

For detailed information on the PC configuration, refer to the M3CON instruction manual.

EXTERNAL & INTERNAL VIEWS

FRONT VIEW

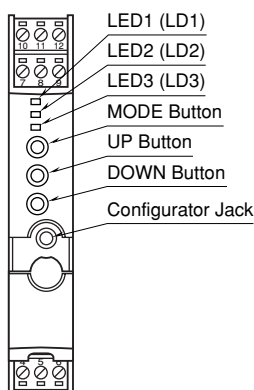

SIDE VIEW

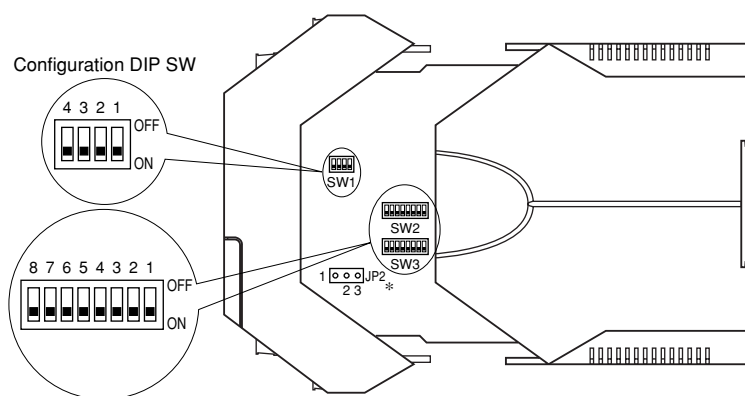

*For Voltage Input (V) range, switch the JP2 jumper to the 2 – 3 position.

Normal Position
(other than DC Voltage [V] range)

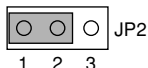

DC Voltage [V] Range Position

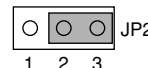

DIP SWITCH SETTINGS

■ CONFIGURATION MODE (SW3)

Table 1

MODE	SW3-8	Configuration mode can be confirmed with the front LED.
DIP SW	OFF	
PC	ON	

■ INPUT TYPE (SW3)

Table 2

INPUT	SW3-7	SW3-6	SW3-5	SW3-4...3-1
DC Current	OFF	OFF	OFF	—
DC mV	OFF	OFF	ON	—
DC Voltage*1	OFF	ON	OFF	—
Thermocouple	OFF	ON	ON	Table 3
RTD	ON	OFF	OFF	Table 4
Potentiometer	ON	OFF	ON	Table 5
Resistance	ON	ON	OFF	—

*1. JP2 position switched from (1 – 2) to (2 – 3) for both DIP SW and PC configuration.

■ THERMOCOUPLE TYPE (SW3)

Table 3

T/C	SW3-4	SW3-3	SW3-2	SW3-1
(PR)	OFF	OFF	OFF	OFF
K (CA)	OFF	OFF	OFF	ON
E (CRC)	OFF	OFF	ON	OFF
J (IC)	OFF	OFF	ON	ON
T (CC)	OFF	ON	OFF	OFF
B (RH)	OFF	ON	OFF	ON
R	OFF	ON	ON	OFF
S	OFF	ON	ON	ON
C (WRe 5-26)	ON	OFF	OFF	OFF
N	ON	OFF	OFF	ON
U	ON	OFF	ON	OFF
L	ON	OFF	ON	ON
P (Platinel II)	ON	ON	OFF	OFF

■ RTD TYPE (SW3)

Table 4

RTD	SW3-4	SW3-3	SW3-2	SW3-1
Pt 100	OFF	OFF	OFF	OFF
Pt 200	OFF	OFF	OFF	ON
Pt 300	OFF	OFF	ON	OFF
Pt 400	OFF	OFF	ON	ON
Pt 500	OFF	ON	OFF	OFF
Pt 1000	OFF	ON	OFF	ON
Pt 50Ω	OFF	ON	ON	OFF
JPt 100	OFF	ON	ON	ON
Ni 100	ON	OFF	OFF	OFF
Ni 120	ON	OFF	OFF	ON
Ni 508.4Ω	ON	OFF	ON	OFF
Ni-Fe 604	ON	OFF	ON	ON
Cu 10 @25°C	ON	ON	OFF	OFF

■ POTENTIOMETER (SW3)

Table 5

RESISTANCE	SW3-4	SW3-3	SW3-2	SW3-1
2500 – 4000Ω	OFF	OFF	OFF	OFF
1200 – 2500Ω	OFF	OFF	OFF	ON
600 – 1200Ω	OFF	OFF	ON	OFF
300 – 600Ω	OFF	OFF	ON	ON
150 – 300Ω	OFF	ON	OFF	OFF
100 – 150Ω	OFF	ON	OFF	ON

■ RTD/RESISTANCE WIRES (SW2)

Table 6

WIRES	SW2-2	SW2-1
2-wire	OFF	OFF
3-wire	OFF	ON
4-wire	ON	ON

■ COLD JUNCTION COMPENSATION (SW2)

Table 7

COLD JUNCTION COMP	SW2-3
Disable	ON
Enable	OFF

■ BURNOUT (SW2)

Table 8

BURNOUT	SW2-5	SW2-4
No burnout	OFF	OFF
Upscale	OFF	ON
Downscale	ON	ON

■ OUTPUT TYPE (SW2 & 1)

Table 9

OUTPUT	SW2-8	SW2-7	SW1-4	SW1-3	SW1-2	SW1-1
0 – 20mA	OFF	OFF	OFF	ON	OFF	OFF
-2.5 – +2.5V	OFF	ON	ON	OFF	OFF	ON
-10 – +10V	ON	OFF	ON	OFF	ON	OFF

■ OUTPUT TYPE / PC CONFIG (SW1)

Table 10

OUTPUT	SW1-4	SW1-3	SW1-2	SW1-1
0 – 20mA	OFF	ON	OFF	OFF
-2.5 – +2.5V	ON	OFF	OFF	ON
-10 – +10V	ON	OFF	ON	OFF

CALIBRATION FLOW CHART

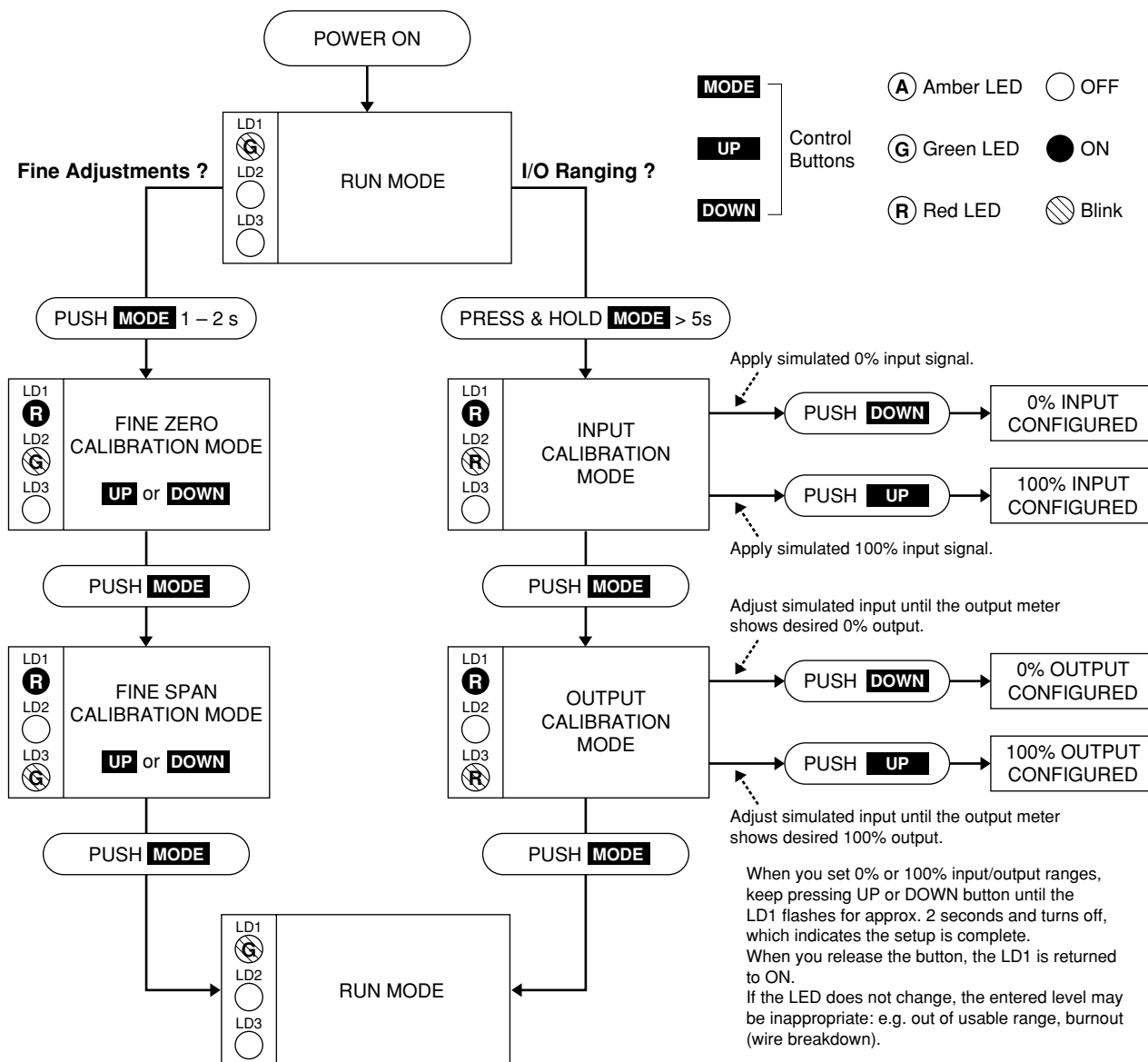

INPUT TYPE, RANGE & ACCURACY

TABLE 11

INPUT TYPE	MIN. SPAN	MAXIMUM RANGE	ACCURACY *1					
DC Current	1mA	0 to 20mA	±0.1%					
DC Millivolt	4mV	-1 to +1V	±10µV at F.S. input ≤50mV ±40µV at F.S. input ≤200mV ±60µV at F.S. input ≤500mV ±80µV at F.S. input >500mV					
DC Voltage	1V	-10 to +10V	±0.1%					
Potentiometer	80Ω	0 to 4000Ω	±0.1%					
Resistance	10Ω	0 to 4000Ω	±0.1Ω					
Thermocouple	°C				°F			
	MIN. SPAN	MAXIMUM RANGE	CONFORMANCE RANGE	ACCURACY *1	MIN. SPAN	MAXIMUM RANGE	CONFORMANCE RANGE	ACCURACY *1
(PR)	20	0 to 1760	0 to 1760	±1.00	36	32 to 3200	32 to 3200	±1.80
K (CA)	20	-270 to +1370	-150 to +1370	±0.25	36	-454 to +2498	-238 to +2498	±0.45
E (CRC)	20	-270 to +1000	-170 to +1000	±0.20	36	-454 to +1832	-274 to +1832	±0.36
J (IC)	20	-210 to +1200	-180 to +1200	±0.25	36	-346 to +2192	-292 to +2192	±0.45
T (CC)	20	-270 to +400	-170 to +400	±0.25	36	-454 to +752	-274 to +752	±0.45
B (RH)	20	100 to 1820	400 to 1760	±0.75	36	212 to 3308	752 to 3200	±1.35
R	20	-50 to +1760	200 to 1760	±0.50	36	-58 to 3200	392 to 3200	±0.90
S	20	-50 to +1760	0 to 1760	±0.50	36	-58 to +3200	32 to 3200	±0.90
C (WRe 5-26)	20	0 to 2315	0 to 2315	±0.25	36	32 to 4199	32 to 4199	±0.45
N	20	-270 to +1300	-130 to +1300	±0.30	36	-454 to +2372	-202 to +2372	±0.54
U	20	-200 to +600	-200 to +600	±0.20	36	-328 to +1112	-328 to +1112	±0.36
L	20	-200 to +900	-200 to +900	±0.25	36	-328 to +1652	-328 to +1652	±0.45
P (Platinel II)	20	0 to 1395	0 to 1395	±0.25	36	32 to 2543	32 to 2543	±0.45
RTD	°C				°F			
	MIN. SPAN	MAXIMUM RANGE		ACCURACY *1	MIN. SPAN	MAXIMUM RANGE		ACCURACY *1
Pt 100 (JIS '97/DIN/IEC)	20	-200 to +850		±0.15	36	-328 to +1562		±0.27
Pt 200	20	-200 to +850		±0.15	36	-328 to +1562		±0.27
Pt 300	20	-200 to +850		±0.15	36	-328 to +1562		±0.27
Pt 400	20	-200 to +850		±0.15	36	-328 to +1562		±0.27
Pt 500	20	-200 to +850		±0.15	36	-328 to +1562		±0.27
Pt 1000	20	-200 to +850		±0.15	36	-328 to +1562		±0.27
Pt 50 (JIS '81)	20	-200 to +649		±0.15	36	-328 to +1200		±0.27
JPt 100 (JIS '89)	20	-200 to +510		±0.15	36	-328 to +950		±0.27
Ni 100	20	-80 to +260		±0.15	36	-112 to +500		±0.27
Ni 120	20	-80 to +260		±0.15	36	-112 to +500		±0.27
Ni 508.4	20	-50 to +200		±0.15	36	-58 to +392		±0.27
Ni-Fe 604	20	-200 to +200		±0.15	36	-328 to +392		±0.27
Cu 10 @25°C	20	-50 to +250		±0.50	36	-58 to +482		±0.90

*1. DC Input: Or ±0.1% of span, whichever is greater.

Thermocouple Input: [Accuracy + Cold Junction Compensation Error 0.5°C (0.9°F)] or ±0.1% of span, whichever is greater.

RTD, Resistance Input: Or ±0.1% of span, whichever is greater.

For current output, overall accuracy degrades another 0.1% with spans ≤2mA.

■ CALCULATION EXAMPLES OF OVERALL ACCURACY IN %

• DC Voltage

1) 0 – 200mV

Absolute value accuracy (Table 11): 40µV

$$40\mu\text{V} / 200000\mu\text{V} \times 100 = 0.02 \% < 0.1\%$$

⇒ Overall accuracy = ±0.1% of span

2) 0 – 4mV

Absolute value accuracy (Table 11): 10µV

$$10\mu\text{V} / 4000\mu\text{V} \times 100 = 0.25 \% > 0.1\%$$

⇒ Overall accuracy = ±0.25% of span

• Thermocouple

1) K thermocouple, 0 – 1000°C

Absolute value accuracy (Table 11): 0.25°C

CJC error (0.5°C) added: 0.75°C

$$0.75\text{°C} / 1000\text{°C} \times 100 = 0.075 \% < 0.1\%$$

⇒ Overall accuracy including CJC error = ±0.1% of span

2) K thermocouple, 50 – 150°C

Absolute value accuracy (Table 11): 0.25°C

CJC error (0.5°C) added: 0.75°C

$$0.75\text{°C} / (150 - 50)\text{°C} \times 100 = 0.75 \% > 0.1\%$$

⇒ Overall accuracy including CJC error = ±0.75% of span

• RTD

1) Pt 100, -200 – 800°C

Absolute value accuracy (Table 11): 0.15°C

$$0.15\text{°C} / (800 - -200)\text{°C} \times 100 = 0.015 \% < 0.1\%$$

⇒ Overall accuracy = ±0.1% of span

2) Pt 100, 0 – 100°C

Absolute value accuracy (Table 11): 0.15°C

$$0.15\text{°C} / 100\text{°C} \times 100 = 0.15 \% > 0.1\%$$

⇒ Overall accuracy = ±0.15% of span