

Space-saving Signal Conditioners *M3-UNIT Series*

STRAIN GAUGE TRANSMITTER
(field- and PC-configurable)

MODEL **M3LLC**

MODEL & SUFFIX CODE SELECTION

M3LLC-□-R4/□□

MODEL

STRAIN GAUGE

S1 : 0.0 – 1.0mV/V

S2 : 0.0 – 3.0mV/V

S3 : 0.0 – 10.0mV/V

S4 : 0.0 – 30.0mV/V

OUTPUT SELECTION

◆DC Current: Usable range 0 – 20mA; min. span 1mA

◆DC Voltage

Narrow Spans: Usable range ±2.5V; min. span 250mV

Wide Spans: Usable range ±10V; min. span 1V

POWER INPUT

R4: 10 – 32V DC

CONFIGURATION OPTIONS

A : PC and field configurable

B : Field configurable

OPTIONS

/UL : UL approval

ORDERING INFORMATION

Specify code number. Orders will be shipped at default factory settings as shown in the table below.

Ordering example:

- Code number (e.g. M3LLC-S1-R4/A)

ITEM		FACTORY SETTING
Input signal	S1	1.0mV
	S2	3.0mV
	S3	10.0mV
	S4	30.0mV
Excitation voltage		1V
Output range		4 – 20mA

RELATED PRODUCTS

- PC configurator software (model: M3CON)
Downloadable at M-System's web site:
<http://www.m-system.co.jp>
- PC configurator cable (model: MCN-CON)

GENERAL SPECIFICATIONS

Connection: Removable terminal block

Housing material: Flame-resistant resin (grey)

Isolation: Input to output to power

Overrange output: Approx. -15 – +115%
(Lower limit: 0mA or -11.5V)

Fine zero and span adjustments: ±15% via the front control buttons

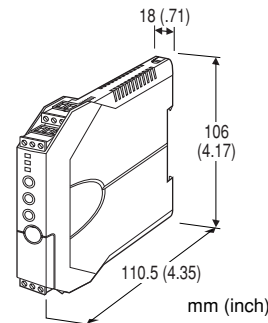

Functions & Features

- Provides a DC output signal proportional to a bridge type strain gauge utilized in load cells and pressure transducers
- Compatibility with strain gauges of various bridge resistances and output ratings
- Supplies required excitation voltage; 0.1 – 10.0V adjustable
- Response time ≤10 msec.
- Easy 'One-Step Cal' calibration using the front three control buttons without needing a PC; PC software is also usable.
- Both input and output type and range are configurable
- UL approval

Typical Applications

- Weighing system for tanks, hoppers and silos
- Weighing system using cranes
- Pressure sensor utilizing strain gauges
- Float level meter utilizing strain gauges

Configuration

'One-Step Cal' calibration: With I/O type and the full-scale range configured via the internal DIP switches, precise 0% and 100% ranges are calibrated via the front control buttons with a help of LED.

PC configurator (model: M3CON): Via Windows PC connected to the front jack.

Programmable features include:

- Input range and output type and range
- Zero and span adjustments

Status indicator LED: Tri-color (green/amber/red) LED; Flashing patterns indicate operation status of the transmitter.

INPUT**■STRAIN GAUGE INPUT****•Strain Gauge****Rated output from strain gauge:**

0.0 – 1.0mV/V
 (-10.0 – +10.0mV, span 1.0 – 10.0mV)
 0.0 – 3.0mV/V
 (-30.0 – +30.0mV, span 3.0 – 30.0mV)
 0.0 – 10.0mV/V
 (-99.9 – +99.9mV, span 10.0 – 99.9mV)
 0.0 – 30.0mV/V
 (-300.0 – +300.0mV, span 30.0 – 300.0mV)

Consult factory for use with a compression/tension load cells.

•Excitation: 0.1 – 10.0V adjustable (0.1V increments)

Maximum current: 30mA

■TARE COMMAND INPUT: TTL level (5V-CMOS level), open collector or dry contact (saturation voltage $\leq 1V$, sink current 0.5mA)

OUTPUT

Output type and range are configurable. See 'Calibration' and 'DIP Switch Setting.'

■DC CURRENT

Maximum range: 0 – 20mA DC

Minimum span: 1mA*

Conformance range: 0 – 20mA DC

Offset: Lower range can be any specific value within the input range provided that the minimum span is maintained.

Load resistance: Output drive 12V maximum at 22mA
 (Range) 0 – 20mA : 600 Ω maximum

*Add 0.1% to the described accuracy for spans narrower than 2mA.

■DC VOLTAGE**Narrow Spans (mV)**

Maximum range: -2.5 – +2.5V DC

Minimum span: 250mV

Conformance range: -3 – +3V DC

Wide Spans (V)

Maximum range: -10 – +10V DC

Minimum span: 1V

Conformance range: -11.5 – +11.5V DC

Offset: Lower range can be any specific value within the input range provided that the minimum span is maintained.

Load resistance: Output drive 10mA maximum; 5mA for negative output

(Range) 0 – 10V : 1k (Ω minimum)
 -10 – 0V : 2k
 0 – 2.5V : 250
 -2.5 – 0V : 500

INSTALLATION

Power input: Operational voltage range 9 – 36V DC; approx. 5W; ripple 10% p-p max.

Operating temperature: -25 to +65°C (-13 to +149°F)
 Max. 55°C (131°F) for UL approval

Operating humidity: 0 to 95% RH (non-condensing)

Mounting: DIN rail

Dimensions: W18×H106×D110.5 mm
 (0.71"×4.17"×4.35")

Weight: 150 g (0.33 lbs)

PERFORMANCE in percentage of span

Accuracy: Input accuracy + output accuracy

Input accuracy: $\pm 0.1\%$

Output accuracy: $\pm 0.1\%$

Temp. coefficient: $\pm 0.015\%/^{\circ}C$ ($\pm 0.008\%/^{\circ}F$)
 at -5 to +55°C [23 to 131°F] of max. range;
 $\pm 0.03\%/^{\circ}C$ ($\pm 0.02\%/^{\circ}F$) at $< -5^{\circ}C$, $> +55^{\circ}C$

Response time: ≤ 10 msec. (0 – 90%)

Excitation voltage setting accuracy: $\pm 250mV$

Line voltage effect: $\pm 0.1\%$ over voltage range

Insulation resistance: $\geq 100M\Omega$ with 500V DC

Dielectric strength: 1500V AC @1 minute
 (input to output or power to ground)
 500V @1 minute (output to power)

STANDARDS & APPROVALS

CE conformity: EMC Directive (89/336/EEC)

EMI EN61000-6-4

EMS EN61000-6-2

Approval: UL/C-UL general safety requirements
 (UL 61010-1, CAN/CSA-C22.2 No.1010-1)

SCHEMATIC CIRCUITRY & CONNECTION DIAGRAM

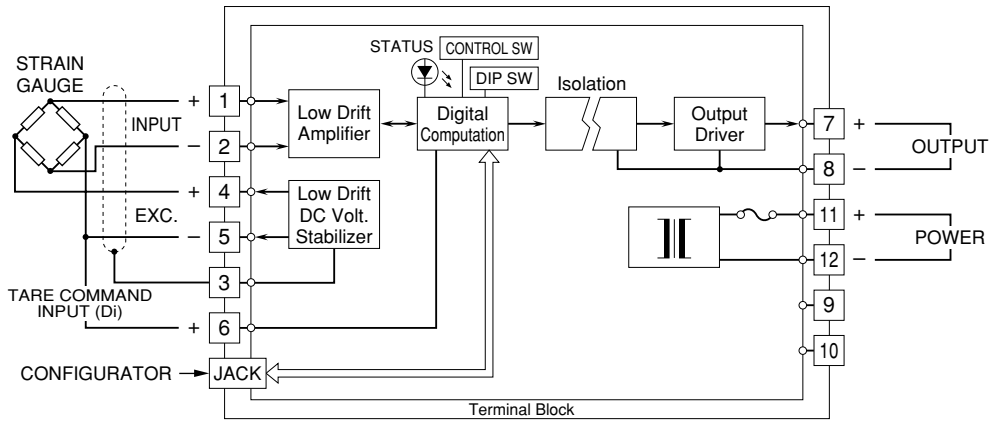

EXTERNAL DIMENSIONS & TERMINAL ASSIGNMENTS mm (inch)

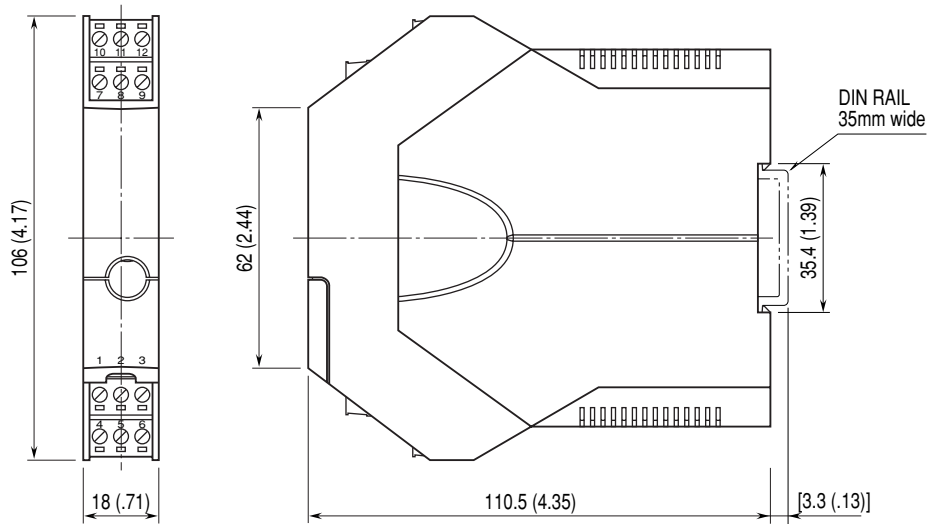

•When mounting, no extra space is needed between units.

EXTERNAL & INTERNAL VIEWS

FRONT VIEW

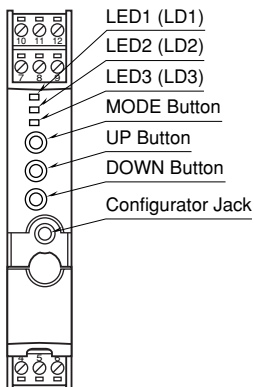

SIDE VIEW

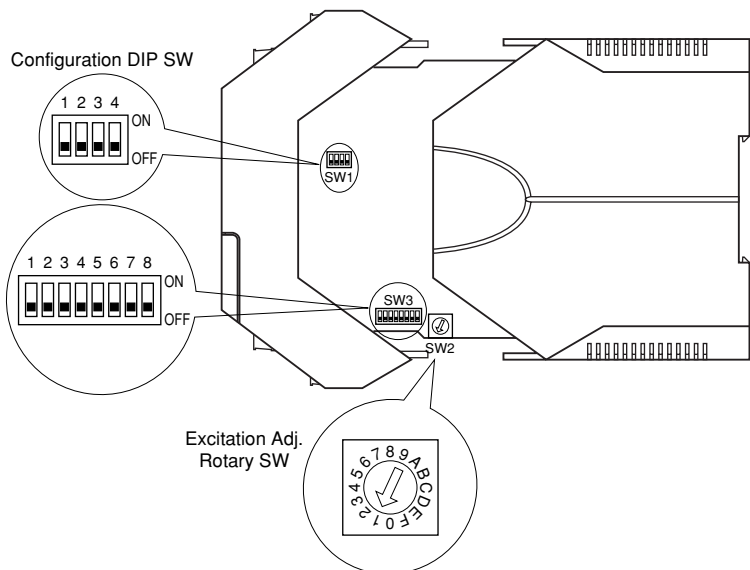

ONE-STEP-CAL CALIBRATION

CONFIGURATION MODES & DIP SW

When you program the transmitter module, two configuration modes are available: Field Configuration using DIP SW / control buttons, and PC Software. (The M3LLC-R4/B is for the field configuration only.)

The internal DIP switches are used to configure excitation and output type. Once the module is configured, precise input and output ranges are set up with the front control buttons using a simulator connected to the input terminals and a multimeter connected to the output terminals as a reference.

INPUT & OUTPUT RANGING

For example, suppose that the DIP switches (model M3LLC-S2, 3mV/V rating) are configured for 5V excitation, and you need to set the input range to 0 – 2mV/V. Turn the power supply to the transmitter on and press MODE button to enter to the Input Calibration Mode. Apply the desired minimum (e.g. 0mV) and maximum (e.g. 10mV) input levels and push the DOWN (zero) and UP (span) respectively to set the input range.

Then the output range can be calibrated in a similar manner after moving to the Output Calibration Mode by pressing MODE button again. Increase or decrease the simulated input until the output meter shows the desired levels and push the DOWN (zero) and UP (span) respectively for the minimum (e.g. 4mA) and maximum (e.g. 20mA) levels.

The front LEDs' colors and flashing patterns help you to easily identify the transmitter's status and confirm the setup actions in each step of Calibration Modes. See detailed explanation in "Calibration Flow Chart."

The calibrated input and output ranges are stored in the internal memory. The module reads the DIP-switch-calibrated configuration (except for the excitation voltage) only once after the power supply is turned on. Set the switches with the power supply removed (except for the excitation voltage).

FINE ZERO & SPAN ADJUSTMENTS

After the transmitter is installed and operational, fine zero and span tuning can be also performed using the front control buttons. Both zero and span are adjustable within $\pm 15\%$.

PC SOFTWARE CONFIGURATION

When you need to apply the same setting to multiple transmitters, downloading one setting from the PC is convenient. The PC Configurator Software (model: M3CON) is available separately.

Turn the transmitter to PC Configuration Mode (See Table 1 to the right) and all programmable features can be set up on a PC regardless of other DIP SW setting except for the output type must be selected with the DIP SW1-1 through SW1-4 (See Table 5).

For detailed information on the PC configuration, refer to the M3CON instruction manual.

DIP SWITCH SETTINGS

■CONFIGURATION MODE (SW3)

Table 1

MODE	SW3-3	Configuration mode can be confirmed with the front LED.
DIP SW	OFF	
PC	ON	

■EXCITATION VOLTAGE, COARSE (SW2)

Table 2

SW2 -	0	1	2	3	4	5	6	7	8	9	A	B	C	D	E	F
Exc. Volts	0	1	2	3	4	5	6	7	8	9	10	11	12	12	12	12

■EXCITATION VOLTAGE, FINE (SW3)

Table 3

POSITION	SW3-5	SW3-6	SW3-7	SW3-8
OFF	+0V	+0V	+0V	+0V
ON	+0.8V	+0.4V	+0.2V	+0.1V

■OUTPUT TYPE (SW3 & 1)

Table 4

OUTPUT	SW3-1	SW3-2	SW1-1	SW1-2	SW1-3	SW1-4
0 – 20mA	OFF	OFF	OFF	OFF	ON	OFF
-2.5 – +2.5V	OFF	ON	ON	OFF	OFF	ON
-10 – +10V	ON	OFF	OFF	ON	OFF	ON

■OUTPUT TYPE / PC CONFIG (SW1)

Table 5

OUTPUT	SW1-1	SW1-2	SW1-3	SW1-4
0 – 20mA	OFF	OFF	ON	OFF
-2.5 – +2.5V	ON	OFF	OFF	ON
-10 – +10V	OFF	ON	OFF	ON

CALIBRATION FLOW CHART

